

1715 Redundant I/O System Specifications

System Module, Catalog Numbers 1715-AENTR, 1715-IB16D, 1715-OB8DE, 1715-IF16, 1715-OF8I

Base Unit, Catalog Numbers 1715-A2A, 1715-A3IO

Termination Assembly, Catalog Numbers 1715-TASIB16D, 1715-TADIB16D, 1715-TASOB8DE, 1715-TADOB8DE, 1715-TASIF16, 1715-TADIF16, 1715-TASOF8, 1715-TADOF8

Accessory, Catalog Numbers 1715-N2S, 1715-N2T, 1715-C2

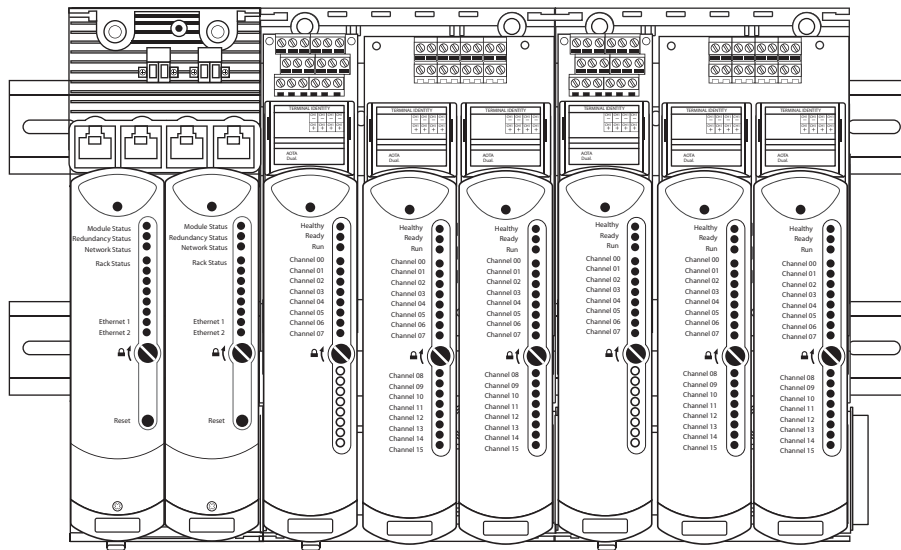

Topic	Page
Conformal Coating Standards	2
1715-AENTR EtherNet/IP Adapter and 1715-A2A Module Base	3
1715-IB16D Digital Input Module, 1715-A3IO Module Base, and Termination Assemblies	6
1715-OB8DE Digital Output Module, 1715-A3IO Module Base, and Termination Assemblies	9
1715-IF16 Analog Input Module, 1715-A3IO Module Base, and Termination Assemblies	12
1715-OF8I Analog Output Module, 1715-A3IO Module Base, and Termination Assemblies	15
Additional Resources	18



Table 1 - 1715 Adapter and Module I/O Base Units

Attribute	1715-A2A	1715-A3IO
Modules supported	Required for 2 x 1715-AENTR modules Supports: • 1 I/O bus • 8 I/O base units (1715-A3IO) • 24 I/O modules	As many as 3 I/O modules
Weight, approx	283 g (9.98 oz)	220 g (7.76 oz)
Dimensions (H x W x D), approx	224 x 84 x 30 mm (8.82 x 3.31 x 1.18 in.)	233 x 126 x 18 mm (6.5 x 1.625 x 4.25 in.)

Table 2 - 1715 Termination Assemblies

Attribute	1715-TASIB16D, 1715-TADIB16D	1715-TASOB8DE, 1715-TADOB8DE	1715-TASIF16, 1715-TADIF16	1715-TASOF8, 1715-TADOF8
Modules supported	1715-IB16D	1715-OB8DE	1715-IF16	1715-OF8
Weight, approx	133 g (4.69 oz), 260 g (9.17 oz)	133 g (4.69 oz), 260 g (9.17 oz)	133 g (4.69 oz), 260 g (9.17 oz)	133 g (4.69 oz), 260 g (9.17 oz)
Fuses	50 mA for each channel	5 A for each supply	50 mA per channel	None
Screw torque	0.5 N•m (0.37 lb•ft)			
Screwdriver width	Flathead 0.4 x 2.0 m (0.0156 x 0.0781 in.)			
Dimensions (H x W x D), approx	1715-TASIB16D, 1715-TASOB8DE, 1715-TASIF16, 1715-TASOF8: 132 x 42 mm (5.25 x 1.65 in.) 1715-TADIB16D, 1715-TADOB8DE, 1715-TADIF16, 1715-TADOF8: 132 x 84 mm (5.25 x 3.375 in.)			

Conformal Coating Standards

The 1715 modules are conformally coated and meet the following standards:

- ANSI/ISA-S71.04-2013; Class G1, G2, and G3 environments
- CEI IEC 60654-4:1987; Class 1, 2, and 3 Environments
- UL746E
- MIL-1-46058C to ASTM-G21 (Tropicalization and fungicide)

1715-AENTR EtherNet/IP Adapter and 1715-A2A Module Base

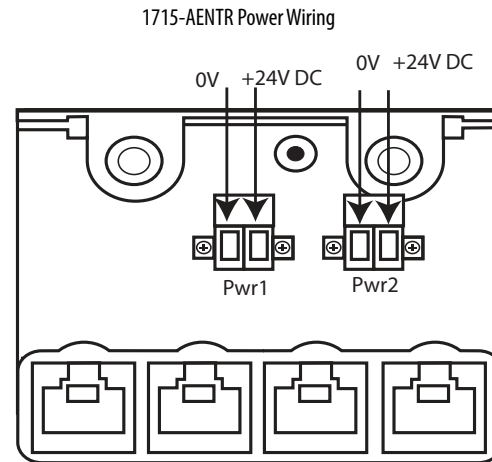
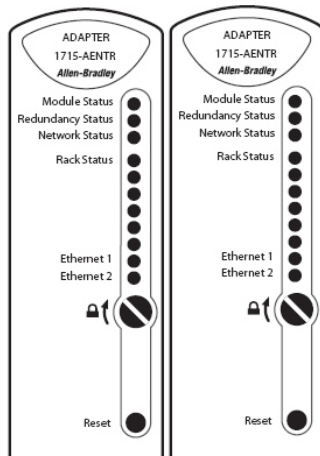

Table 3 - Technical Specifications - 1715-AENTR EtherNet/IP Adapter and 1715-A2A Module Base

Attribute	1715-AENTR and 1715-A2A
Modules supported, max	24 per adapter pair
Operating voltage range, supply power and/or current ratings	1715-AENTR backplane: 380 mA @18...32V DC 1715-A2A input power: 10.4 A total max/400 mA max per slot @ 18...32V DC For fault-tolerant applications, the I/O module power is less than 3.2 A
Power dissipation	8 W max, per adapter
Isolation voltage	50V (continuous), basic insulation type, Ethernet ports to backplane and Ethernet ports to DC power ports No isolation between individual Ethernet ports No isolation between DC power ports Type tested @ 500V AC for 60 s
Base unit	1715-A2A (2-slot adapter base unit)
Weight, approx	1715-AENTR module: 420 g (14.82 oz) 1715-A2A base unit: 283 g (9.98 oz)
Fuse, type	4 A, 125V, Type T
Wiring category	2 - on power ports 2 - on communication ports ⁽¹⁾
Wire size	1715-A2A DC Power connections: single 2.5 mm ² (12 AWG) solid or stranded copper wire rated at 85 °C (185 °F) or greater, 7 mm (9/32 in.) strip length 1715-A2A Ground connection: 4 mm ² (10 AWG) min
Wire type	1715-A2A Ethernet connections: Shielded RJ45 connector according to IEC60603-7, 2-pair or 4-pair shielded Category 5e min cable according to TIA 568-B 1 or shielded Category 5 cable according to ISO/IEC 24702
North American temperature code	T4
IEC temperature code	T4
Enclosure type rating	None (open-style)

(1) Use this conductor category information for planning conductor routing as described in the system level installation manual. See the Industrial Automation Wiring and Grounding Guidelines, publication [1770-4.1](#).

Table 4 - Environmental Specifications - 1715-AENTR EtherNet/IP Adapter and 1715-A2A Module Base

Attribute	1715-AENTR and 1715-A2A
Temperature, operating IEC 60068-2-1 (Test Ad, Operating Cold), IEC 60068-2-2 (Test Bd, Operating Dry Heat), IEC 60068-2-14 (Test Nb, Operating Thermal Shock)	-25...60 °C (-13...140 °F)
Temperature, surrounding air max	60 °C (140 °F)
Temperature, nonoperating IEC 60068-2-1 (Test Ab, Unpackaged Nonoperating Cold), IEC 60068-2-2 (Test Bb, Unpackaged Nonoperating Dry Heat), IEC 60068-2-14 (Test Na, Unpackaged Nonoperating Thermal Shock)	-40...85 °C (-40...185 °F)
Relative humidity IEC 60068-2-30 (Test Db, Unpackaged Nonoperating Damp Heat)	10...95% noncondensing
Vibration IEC 60068-2-6 (Test Fc, Operating)	2 g @ 10...500 Hz
Shock, operating IEC 60068-2-27 (Test Ea, Unpackaged Shock)	Din rail mount: 25 g Panel mount: 30 g
Shock, nonoperating IEC 60068-2-27 (Test Ea, Unpackaged Shock)	Installed: 30 g Uninstalled: 50 g (with slot fillers)
Emissions CISPR 11 (IEC 61000-6-4)	Class A
ESD immunity IEC 61000-4-2	6 kV contact discharges 8 kV air discharges
Radiated RF immunity IEC 61000-4-3	20V/m with 1 kHz sine-wave 80% AM from 80...1000 MHz 10V/m with 1 kHz sine-wave 80% AM from 1000...2000 MHz 10V/m with 200 Hz 50% Pulse 100% AM @ 900 MHz 10V/m with 200 Hz 50% Pulse 100% AM @ 1890 MHz 3V/m with 1 kHz sine-wave 80% AM from 2000...2700 MHz
EFT/B immunity IEC 61000-4-4	±3 kV at 5 kHz on power ports ±2 kV at 5 kHz on shielded Ethernet ports
Surge transient immunity IEC 61000-4-5	±1 kV line-line (DM) and ±2 kV line-earth (CM) on power ports ±2 kV line-earth (CM) on shielded Ethernet ports
Conducted RF immunity IEC 61000-4-6	10V rms with 1 kHz sine-wave 80% AM from 150 kHz...80 MHz

Table 5 - Certifications - 1715-AENTR EtherNet/IP Adapter and 1715-A2A Module Base

Certification ⁽¹⁾	1715-AENTR and 1715-A2A
cULus	UL Listed Industrial Control Equipment, certified for US and Canada. See UL File E341697. UL Listed for Class I, Division 2 Group A,B,C,D Hazardous Locations, certified for U.S. and Canada. See UL File E251761.
CE	European Union 2004/108/EC EMC Directive, compliant with: <ul style="list-style-type: none"> EN 61326-1; Meas./Control/Lab., Industrial Requirements EN 61000-6-2; Industrial Immunity EN 61000-6-4; Industrial Emissions EN 61131-2; Programmable Controllers (Clause 8, Zone A & B)
C-Tick	Australian Radiocommunications Act, compliant with: AS/NZS CISPR 11; Industrial Emissions
Ex	European Union 94/9/EC ATEX Directive, compliant with: <ul style="list-style-type: none"> EN 60079-15; Potentially Explosive Atmospheres, Protection 'n' EN 60079-0; General Requirements II 3 G Ex nA IICT4 Gc X DEMKO 11 ATEX 7928686X

Table 5 - Certifications - 1715-AENTR EtherNet/IP Adapter and 1715-A2A Module Base

Certification ⁽¹⁾	1715-AENTR and 1715-A2A
IECEX	IECEX Hazardous Location approval, compliant with: <ul style="list-style-type: none"> • IEC 60079-0: Ed 6 Explosive Atmospheres - General Requirements • IEC 60079-15: Ed 4 Explosive Atmospheres - Protection 'n' • IECEx UL 15.0032X
KC	Korean Registration of Broadcasting and Communications Equipment, compliant with: Article 58-2 of Radio Waves Act, Clause 3
EtherNet/IP	ODVA conformance tested to EtherNet/IP specifications
Functional Safety	TÜV Certified for Functional Safety ⁽²⁾ : Capable of SIL 2 according to EN 62061, IEC 61508, and EN 61326-3-1

(1) When marked. See the Product Certification link at <http://www.ab.com> for Declarations of Conformity, Certificates, and other certification details.

(2) When used with specified firmware revisions.

1715-IB16D Digital Input Module, 1715-A3IO Module Base, and Termination Assemblies

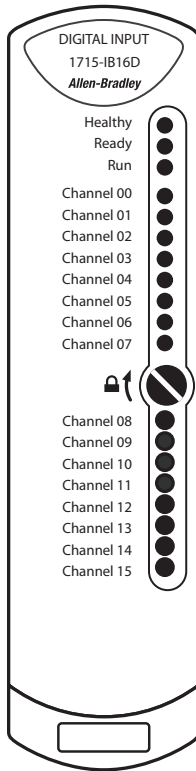

32065-M

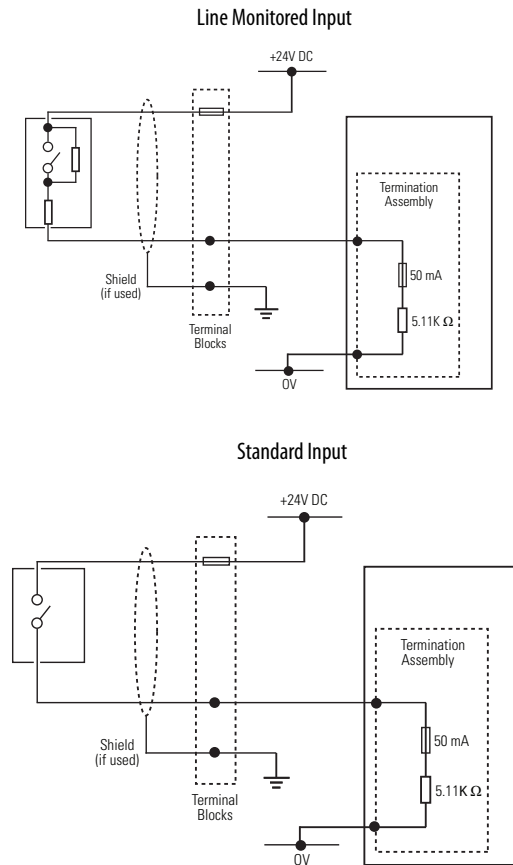

Table 6 - Technical Specifications - 1715-IB16D Digital Input Module, 1715-A3IO Module Base, and 1715-TASIB16D, 1715-TADIB16D Termination Assemblies

Attribute	1715-IB16D, 1715-A3IO, 1715-TASIB16D, 1715-TADIB16D
Operating voltage range, supply power and/or current ratings	1715-IB16D backplane: 260 mA @ 18...32V DC 1715-TASIB16D, 1715-TAD8B16D: 6.5 mA per channel @ 0...32V DC
Slew rate, max	3600 V/s ⁽¹⁾
Translation rate, max	1/(Application scan time + 10 ms) Hz ⁽¹⁾
Power dissipation	7.2 W, max (module and termination assembly combined)
Isolation voltage	50V (continuous), basic insulation type, I/O ports to backplane No isolation between individual I/O ports if the 1715-TASIB16D termination assembly is fitted 50V isolation between individual ports if 1715-TADIB16D termination assembly is fitted Type tested at 500V AC for 60 s
Weight, approx	1715-IB16D: 360 g (12.70 oz) I/O base unit: 133 g (5 oz) Termination assembly: 133 g (5 oz), 260 g (10 oz)
Dimensions (H x W x D), approx	166 x 42 x 118 mm (6.5 x 1.625 x 4.625 in.)
Wire size	1715-TASIB16D, 1715-TADIB16D connections: 0.33...1.5 mm ² (22...16 AWG) solid or stranded copper wire rated at 85 °C (185 °F), or greater
Wiring category	2 - on signal ports ⁽²⁾

Table 6 - Technical Specifications - 1715-IB16D Digital Input Module, 1715-A3IO Module Base, and 1715-TASIB16D, 1715-TADIB16D Termination Assemblies

Attribute	1715-IB16D, 1715-A3IO, 1715-TASIB16D, 1715-TADIB16D
Fuse, type	50 mA, 125V, Type T
North American temperature code	T4
IEC temperature code	T4
Enclosure type	None (open-style)

- (1) The input slew can exceed the specified levels if the duration of the transgression is less than the process safety time of the configured module. Transgression of the slew rate limits identified previously can lead to channel failure that results from diagnostics that are otherwise designed to ensure channels are operating within their defined safety accuracy.
- (2) Use this conductor category information for planning conductor routing as described in the system-level installation manual. See the Industrial Automation Wiring and Grounding Guidelines, publication [1770-4.1](#).

Table 7 - Environmental Specifications - 1715-IB16D Digital Input, 1715-A3IO Module Base, and 1715-TASIB16D, 1715-TADIB16D Termination Assemblies

Attribute	1715-IB16D, 1715-A3IO, 1715-TASIB16D, 1715-TADIB16D
Temperature, operating IEC 60068-2-1 (Test Ad, Operating Cold), IEC 60068-2-2 (Test Bd, Operating Dry Heat), IEC 60068-2-14 (Test Nb, Operating Thermal Shock)	-25...70 °C (-13...158 °F)
Temperature, surrounding air, max	70 °C (158 °F)
Temperature, nonoperating IEC 60068-2-1 (Test Ab, Unpackaged Nonoperating Cold), IEC 60068-2-2 (Test Bb, Unpackaged Nonoperating Dry Heat), IEC 60068-2-14 (Test Na, Unpackaged Nonoperating Thermal Shock)	-40...85 °C (-40...185 °F)
Relative humidity IEC 60068-2-30 (Test Db, Unpackaged Nonoperating Damp Heat)	10...95% noncondensing
Vibration IEC 60068-2-6 (Test Fc, Operating)	2 g @ 10...500 Hz
Shock, operating IEC 60068-2-27 (Test Ea, Unpackaged Shock)	DIN rail mount: 25 g Panel mount: 30 g
Shock, nonoperating IEC 60068-2-27 (Test Ea, Unpackaged Shock)	Installed: 30 g Uninstalled: 50 g (with slot fillers)
Emissions CISPR 11 (IEC 61000-6-4)	Class A
ESD immunity IEC 61000-4-2	6 kV contact discharges 8 kV air discharges
Radiated RF immunity IEC 61000-4-3	20V/m with 1 kHz sine-wave 80% AM from 80...1000 MHz 10V/m with 1 kHz sine-wave 80% AM from 1000...2000 MHz 10V/m with 200 Hz 50% Pulse 100% AM @ 900 MHz 10V/m with 200 Hz 50% Pulse 100% AM @ 1890 MHz 3V/m with 1 kHz sine-wave 80% AM from 2000...2700 MHz
EFT/B immunity IEC 61000-4-4	±2 kV @ 5 kHz on signal ports
Surge transient immunity IEC 61000-4-5	±1 kV line-line (DM) and ±2 kV line-earth (CM) on signal ports
Conducted RF immunity IEC 61000-4-6	10V rms with 1 kHz sine-wave 80% AM from 150 kHz...80 MHz

Table 8 - Certifications - 1715-IB16D Digital Input, 1715-A3IO Module Base, and 1715-TASIB16D, 1715-TADIB16D Termination Assemblies

Certification ⁽¹⁾	1715-IB16D, 1715-A3IO, 1715-TASIB16D, 1715-TADIB16D
cULus	UL Listed Industrial Control Equipment, certified for US and Canada. See UL File E341697. UL Listed for Class I, Division 2 Group A,B,C,D Hazardous Locations, certified for U.S. and Canada. See UL File E251761.
CE	European Union 2004/108/EC EMC Directive, compliant with: <ul style="list-style-type: none"> • EN 61326-1; Meas./Control/Lab., Industrial Requirements • EN 61000-6-2; Industrial Immunity • EN 61000-6-4; Industrial Emissions • EN 61131-2; Programmable Controllers (Clause 8, Zone A & B)
C-Tick	Australian Radiocommunications Act, compliant with: AS/NZS CISPR 11; Industrial Emissions
Ex	European Union 94/9/EC ATEX Directive, compliant with: <ul style="list-style-type: none"> • EN 60079-15; Potentially Explosive Atmospheres, Protection 'n' • EN 60079-0; General Requirements II 3 G Ex nA IIC T4 Gc X • DEMKO 11 ATEX 7928686X
IECEx	IECEx Hazardous Location approval, compliant with: <ul style="list-style-type: none"> • IEC 60079-0: Ed 6 Explosive Atmospheres - General Requirements • IEC 60079-15: Ed 4 Explosive Atmospheres - Protection 'n' • IECEx UL 15.0032X
KC	Korean Registration of Broadcasting and Communications Equipment, compliant with: Article 58-2 of Radio Waves Act, Clause 3
Functional Safety	TÜV Certified for Functional Safety ⁽²⁾ : Capable of SIL 2 according to EN 62061, IEC 61508, and EN 61326-3-1

(1) When marked. See the Product Certification link at <http://www.ab.com> for Declarations of Conformity, Certificates, and other certification details.

(2) When used with specified firmware revisions.

1715-OB8DE Digital Output Module, 1715-A310 Module Base, and Termination Assemblies

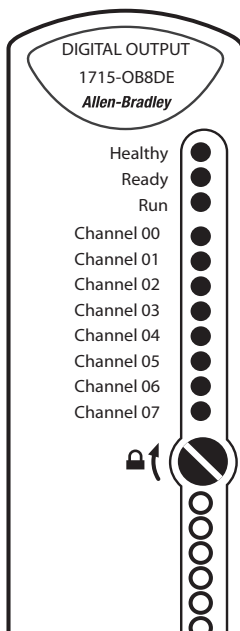

32090-M

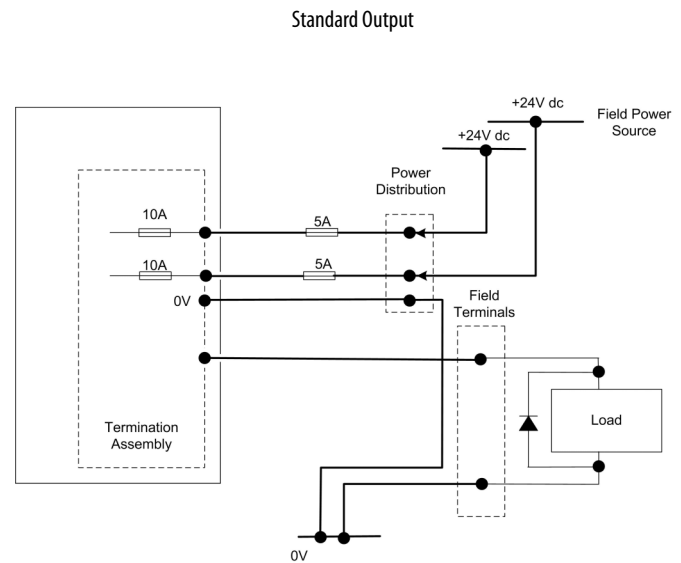

33002-M

Table 9 - Technical Specifications - 1715-OB8DE Digital Output Module, 1715-A310 Module Base, and 1715-TASOB8DE, 1715-TADOB8DE Termination Assemblies

Attribute	1715-OB8DE, 1715-A310, 1715-TASOB8DE, 1715-TADOB8DE
Operating voltage range, supply power and/or current ratings	1715-OB8DE backplane: 165 mA @ 18...32V DC 1715-TASOB8DE, 1715-TADOB8DE I/O: 0.5 A per channel @ 18...32V DC
Field voltage slew rate, max	150 V/s ^{(1),(2)}
De-energized output voltage slew rate, max	12 V/ms ⁽³⁾
Energized output current slew rate, max	0.9 A/ms ⁽³⁾
Power dissipation	System: 3.0 W max Field Loop: 0.17 W per field loop
Isolation voltage	50V (continuous), basic insulation type, I/O ports to backplane No isolation between individual I/O ports Type tested at 500V AC for 60 s
Weight, approx	1715-OB8DE module: 290 g (10.23 oz) I/O base unit: 133 g (5 oz) Termination assembly: 133 g (5 oz), 260 g (10 oz)
Dimensions (H x W x D), approx	166 x 42 x 118 mm (6.5 x 1.625 x 4.625 in.)
Wire size	1715-TASOB8DE, 1715-TADOB8DE connections: Single 0.75...1.5 mm ² (18...16 AWG) solid or stranded copper wire rated at 85 °C (185 °F), or greater
Wiring category	2 - on signal ports ⁽⁴⁾
Fuse, type	1715-TASOB8DE, 1715-TADOB8DE I/O: 10 A, 125V, Type F 1715-TASOB8DE, 1715-TADOB8DE I/O Power Source: 5 A max, 32V DC, min
Pilot duty rating	16VA, 1.5 inrush

Table 9 - Technical Specifications - 1715-OB8DE Digital Output Module, 1715-A3IO Module Base, and 1715-TASOB8DE, 1715-TADOB8DE Termination Assemblies

Attribute	1715-OB8DE, 1715-A3IO, 1715-TASOB8DE, 1715-TADOB8DE
North American temperature code	T4
IEC temperature code	T4
Enclosure type	None (open-style)

- (1) Limit not applicable if all outputs are energized.
- (2) Limit not applicable if perturbations are less than $2.0 V_{pp}$ or last less than 3 minutes in any 60 minute period.
- (3) Limit not applicable to transgressions that last less than the process safety time configured for the module.
Transgression of the slew rate limits identified previously can lead to channel failure that results from diagnostics that are otherwise designed to ensure channels are operating within their defined safety accuracy.
- (4) Use this conductor category information for planning conductor routing as described in the system-level installation manual. See the Industrial Automation Wiring and Grounding Guidelines, publication [1770-4.1](#).

Table 10 - Environmental Specifications - 1715-OB8DE Digital Output Module, 1715-A3IO Module Base, and 1715-TASOB8DE, 1715-TASOB8DE Termination Assemblies

Attribute	1715-OB8DE, 1715-A3IO, 1715-TASOB8DE, 1715-TADOB8DE
Temperature, operating IEC 60068-2-1 (Test Ad, Operating Cold), IEC 60068-2-2 (Test Bd, Operating Dry Heat), IEC 60068-2-14 (Test Nb, Operating Thermal Shock)	-25...70 °C (-13...158 °F)
Temperature, surrounding air, max	70 °C (158 °F)
Temperature, nonoperating IEC 60068-2-1 (Test Ab, Unpackaged Nonoperating Cold), IEC 60068-2-2 (Test Bb, Unpackaged Nonoperating Dry Heat), IEC 60068-2-14 (Test Na, Unpackaged Nonoperating Thermal Shock)	-40...85 °C (-40...185 °F)
Relative humidity IEC 60068-2-30 (Test Db, Unpackaged Nonoperating Damp Heat)	10...95% noncondensing
Vibration IEC 60068-2-6 (Test Fc, Operating)	2 g @ 10...500 Hz
Shock, operating IEC 60068-2-27 (Test Ea, Unpackaged Shock)	DIN rail mount: 25 g Panel mount: 30 g
Shock, nonoperating IEC 60068-2-27 (Test Ea, Unpackaged Shock)	Installed: 30 g Uninstalled: 50 g (with slot fillers)
Emissions CISPR 11 (IEC 61000-6-4)	Class A
ESD immunity IEC 61000-4-2	6 kV contact discharges 8 kV air discharges
Radiated RF immunity IEC 61000-4-3	20V/m with 1 kHz sine-wave 80% AM from 80...1000 MHz 10V/m with 1 kHz sine-wave 80% AM from 1000...2000 MHz 10V/m with 200 Hz 50% Pulse 100% AM @ 900 MHz 10V/m with 200 Hz 50% Pulse 100% AM @ 1890 MHz 3V/m with 1 kHz sine-wave 80% AM from 2000...2700 MHz
EFT/B immunity IEC 61000-4-4	±2 kV @ 5 kHz on signal ports
Surge transient immunity IEC 61000-4-5	±1 kV line-line (DM) and ±2 kV line-earth (CM) on signal ports
Conducted RF immunity IEC 61000-4-6	10V rms with 1 kHz sine-wave 80% AM from 150 kHz...80 MHz

Table 11 - Certifications - 1715-OB8DE Digital Output Module, 1715-A3IO Module Base, and 1715-TASOB8DE, 1715-TASOB8DE Termination Assemblies

Certification ⁽¹⁾	1715-OB8DE, 1715-A3IO, 1715-TASOB8DE, 1715-TADOB8DE
cULus	UL Listed Industrial Control Equipment, certified for US and Canada. See UL File E341697. UL Listed for Class I, Division 2 Group A,B,C,D Hazardous Locations, certified for U.S. and Canada. See UL File E251761.
CE	European Union 2004/108/EC EMC Directive, compliant with: <ul style="list-style-type: none"> EN 61326-1; Meas./Control/Lab., Industrial Requirements EN 61000-6-2; Industrial Immunity EN 61000-6-4; Industrial Emissions EN 61131-2; Programmable Controllers (Clause 8, Zone A & B)
C-Tick	Australian Radiocommunications Act, compliant with: AS/NZS CISPR 11; Industrial Emissions
Ex	European Union 94/9/EC ATEX Directive, compliant with: <ul style="list-style-type: none"> EN 60079-15; Potentially Explosive Atmospheres, Protection 'n' EN 60079-0; General Requirements II 3 G Ex nA IIC T4 Gc X DEMKO 11 ATEX 7928686X
IECEx	IECEx Hazardous Location approval, compliant with: <ul style="list-style-type: none"> IEC 60079-0: Ed 6 Explosive Atmospheres - General Requirements IEC 60079-15: Ed 4 Explosive Atmospheres - Protection 'n' IECEx UL 15.0032X
KC	Korean Registration of Broadcasting and Communications Equipment, compliant with: Article 58-2 of Radio Waves Act, Clause 3
Functional Safety	TÜV Certified for Functional Safety ⁽²⁾ : Capable of SIL 2 according to EN 62061, IEC 61508, and EN 61326-3-1

(1) When marked. See the Product Certification link at <http://www.ab.com> for Declarations of Conformity, Certificates, and other certification details.

(2) When used with specified firmware revisions.

1715-IF16 Analog Input Module, 1715-A310 Module Base, and Termination Assemblies

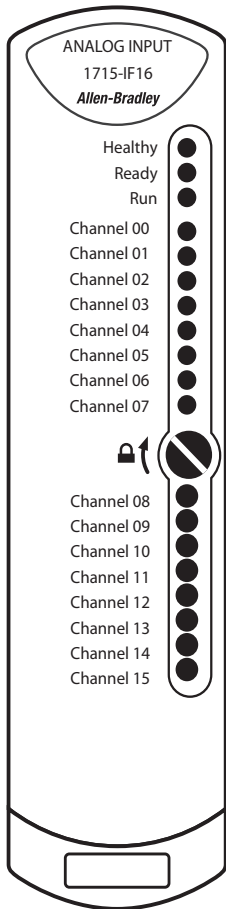

32091-M

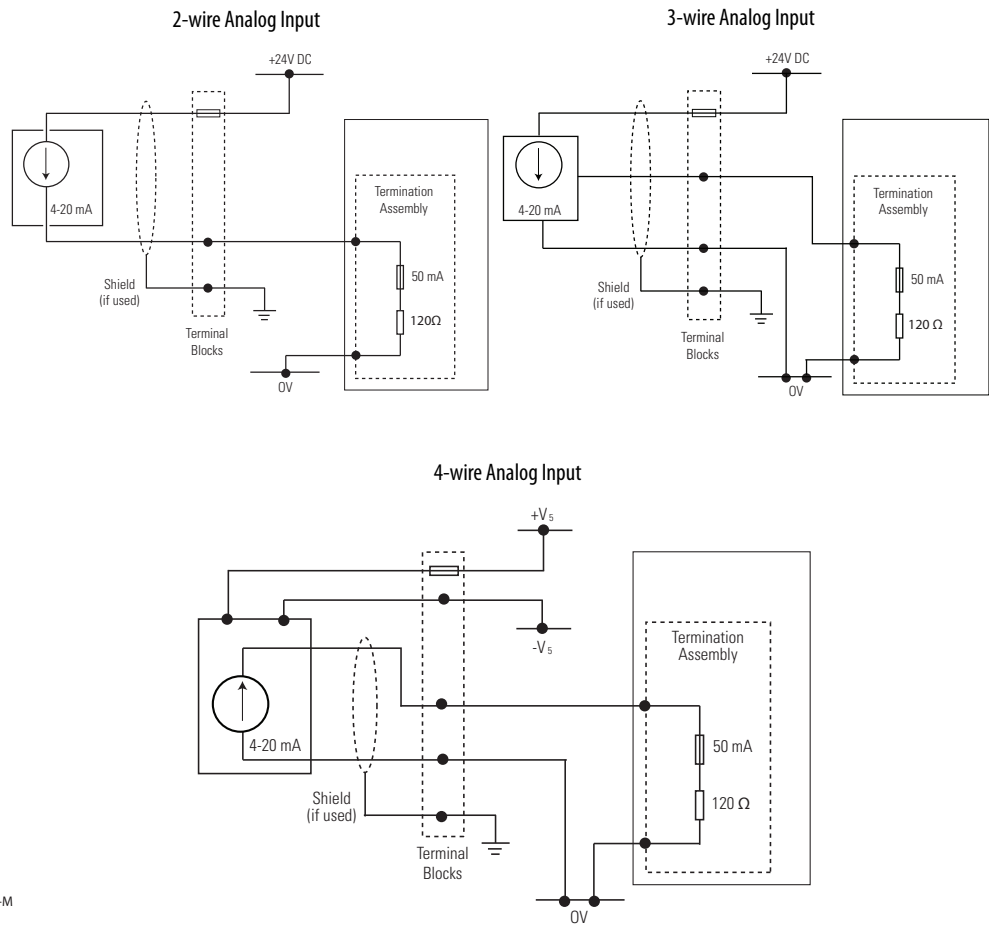

Table 12 - Technical Specifications - 1715-IF16 Analog Input Module, 1715-A310 Module Base, and 1715-TASIF16, 1715-TADIF16 Termination Assemblies

Attribute	1715-IF16, 1715-A310, 1715-TASIF16, 1715-TADIF16
Operating voltage range, supply power and/or current ratings	1715-IF16 backplane: 260 mA @ 18...32V DC 1715-TASIF16, 1715-TADIF16 I/O: 0...24 mA per channel @ 18...32V DC
Slew rate, max	700 mA/s ⁽¹⁾
Power dissipation	5.28 W, max (module and termination assembly combined)
Isolation voltage	50V (continuous), basic insulation type, I/O ports to backplane No isolation between individual I/O ports if the 1715-TASIF16 termination assembly is fitted 50V isolation between individual ports if 1715-TADIF16 termination assembly is fitted Type tested at 500V AC for 60 s
Input resolution	0.0039 mA/cnt (12 bits over 4...20 mA range)
Weight, approx	1715-IF16 module: 360 g (12.70 oz) I/O base unit: 133 g (5 oz) Termination assembly: 133 g (5 oz), 260 g (10 oz)
Dimensions (H x W x D), approx	166 x 42 x 118 mm (6.5 x 1.625 x 4.625 in.)

Table 12 - Technical Specifications - 1715-IF16 Analog Input Module, 1715-A310 Module Base, and 1715-TASIF16, 1715-TADIF16 Termination Assemblies

Attribute	1715-IF16, 1715-A310, 1715-TASIF16, 1715-TADIF16
Wire size	1715-TASIF16, 1715-TADIF16 I/O connections: Single 0.33...1.5 mm ² (22...16 AWG) solid or stranded shielded copper wire rated at 85 °C (185 °F), or greater
Wiring category	2 - on shielded signal ports ⁽²⁾
Fuse, type	1715-TASIF16, 1715-TADIF16 I/O: 50 mA, 125V, Type T
Wire type	Shielded
North American temperature code	T4
IEC temperature code	T4
Enclosure type	None (open-style)

- (1) The input slew can exceed the specified level if the duration of the transgression is less than the process safety time of the configured module. Transgression of the slew rate limits identified previously can lead to channel failure that results from diagnostics that are otherwise designed to ensure channels are operating within their defined safety accuracy.
- (2) Use this conductor category information for planning conductor routing as described in the system-level installation manual. See the Industrial Automation Wiring and Grounding Guidelines, publication [1770-4.1](#).

Table 13 - Environmental Specifications - 1715-IF16 Analog Input Module, 1715-A310 Module Base, and 1715-TASIF16, 1715-TADIF16 Termination Assemblies

Attribute	1715-IF16, 1715-A310, 1715-TASIF16, 1715-TADIF16
Temperature, operating IEC 60068-2-1 (Test Ad, Operating Cold), IEC 60068-2-2 (Test Bd, Operating Dry Heat), IEC 60068-2-14 (Test Nb, Operating Thermal Shock)	-25...70 °C (-13...158 °F)
Temperature, surrounding air, max	70 °C (158 °F)
Temperature, nonoperating IEC 60068-2-1 (Test Ab, Unpackaged Nonoperating Cold), IEC 60068-2-2 (Test Bb, Unpackaged Nonoperating Dry Heat), IEC 60068-2-14 (Test Na, Unpackaged Nonoperating Thermal Shock)	-40...85 °C (-40...185 °F)
Relative humidity IEC 60068-2-30 (Test Db, Unpackaged Nonoperating Damp Heat)	10...95% noncondensing
Vibration IEC 60068-2-6 (Test Fc, Operating)	2 g @ 10...500 Hz
Shock, operating IEC 60068-2-27 (Test Ea, Unpackaged Shock)	DIN rail mount: 25 g Panel mount: 30 g
Shock, nonoperating IEC 60068-2-27 (Test Ea, Unpackaged Shock)	Installed: 30 g Uninstalled: 50 g (with slot fillers)
Emissions CISPR 11 (IEC 61000-6-4)	Class A
ESD immunity IEC 61000-4-2	6 kV contact discharges 8 kV air discharges
Radiated RF immunity IEC 61000-4-3	20V/m with 1 kHz sine-wave 80% AM from 80...1000 MHz 10V/m with 1 kHz sine-wave 80% AM from 1000...2000 MHz 10V/m with 200 Hz 50% Pulse 100% AM @ 900 MHz 10V/m with 200 Hz 50% Pulse 100% AM @ 1890 MHz 3V/m with 1 kHz sine-wave 80% AM from 2000...2700 MHz

Table 13 - Environmental Specifications - 1715-IF16 Analog Input Module, 1715-A310 Module Base, and 1715-TASIF16, 1715-TADIF16 Termination Assemblies

Attribute	1715-IF16, 1715-A310, 1715-TASIF16, 1715-TADIF16
EFT/B immunity IEC 61000-4-4	±2 kV @ 5 kHz on shielded signal ports
Surge transient immunity IEC 61000-4-5	±2 kV line-earth (CM) on shielded signal ports
Conducted RF immunity IEC 61000-4-6	10V rms with 1 kHz sine-wave 80% AM from 150 kHz. . . 80 MHz

Table 14 - Certifications - 1715-IF16 Analog Input Module, 1715-A310 Module Base, and 1715-TASIF16, 1715-TADIF16 Termination Assemblies

Certification ⁽¹⁾	1715-IF16, 1715-A310, 1715-TASIF16, 1715-TADIF16
cULus	UL Listed Industrial Control Equipment, certified for US and Canada. See UL File E341697.
UL	UL Listed for Class I, Division 2 Group A,B,C,D Hazardous Locations, certified for U.S. and Canada. See UL File E251761.
CE	European Union 2004/108/EC EMC Directive, compliant with: <ul style="list-style-type: none"> EN 61326-1; Meas./Control/Lab., Industrial Requirements EN 61000-6-2; Industrial Immunity EN 61000-6-4; Industrial Emissions EN 61131-2; Programmable Controllers (Clause 8, Zone A & B)
C-Tick	Australian Radiocommunications Act, compliant with: AS/NZS CISPR 11; Industrial Emissions
Ex	European Union 94/9/EC ATEX Directive, compliant with: <ul style="list-style-type: none"> EN 60079-15; Potentially Explosive Atmospheres, Protection 'n' EN 60079-0; General Requirements II 3 G Ex nA IIC T4 Gc X DEMKO 11 ATEX 7928686X
IECEX	IECEX Hazardous Location approval, compliant with: <ul style="list-style-type: none"> IEC 60079-0: Ed 6 Explosive Atmospheres - General Requirements IEC 60079-15: Ed 4 Explosive Atmospheres - Protection 'n' IECEX UL 15.0032X
KC	Korean Registration of Broadcasting and Communications Equipment, compliant with: Article 58-2 of Radio Waves Act, Clause 3
Functional Safety	TÜV Certified for Functional Safety ⁽²⁾ : Capable of SIL 2 according to EN 62061, IEC 61508, and EN 61326-3-1

(1) When marked. See the Product Certification link at <http://www.ab.com> for Declarations of Conformity, Certificates, and other certification details.

(2) When used with specified firmware revisions.

1715-OF8I Analog Output Module, 1715-A3I0 Module Base, and Termination Assemblies

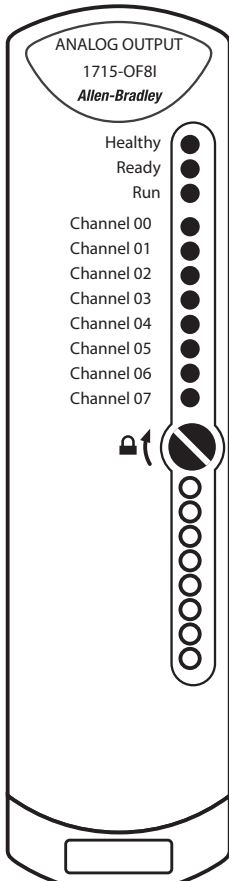

32089-M

Analog Output Field Loop Circuit

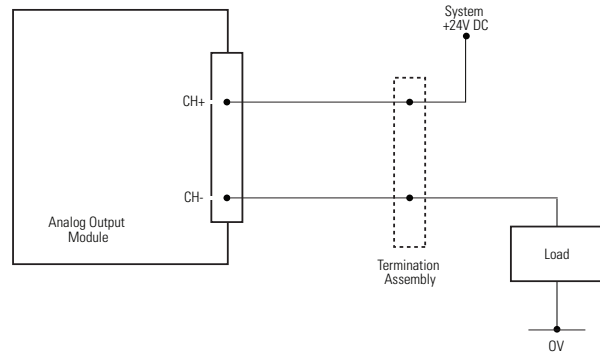

Analog Output Field Power Circuit

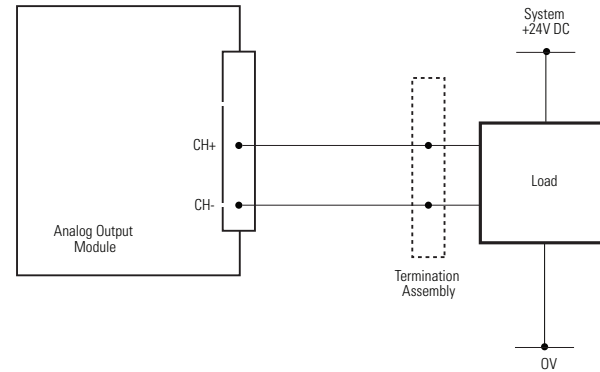

Table 15 - Technical Specifications - 1715-OF8I Analog Output Module, 1715-A3I0 Module Base, and 1715-TASOF8I, 1715-TADOF8I Termination Assemblies

Attribute	1756-OF8I, 1715-A3I0, 1715-TASOF8, 1715-TADOF8
Operating voltage range, supply power and/or current ratings	1715-OF8I backplane: 260 mA @ 18...32V DC 1715-TASOF8, 1715-TADOF8 I/O: 0...24 mA per channel @ 18...32V DC
Compliance voltage slew rate, max	No limit identified within compliance voltage range
Power dissipation	System: 3.3 W max Field Loop: 0.64 W per field loop
Isolation voltage	50V (continuous), basic insulation type, I/O ports to backplane 50V isolation between individual I/O ports Type tested at 500V AC for 60 s
Weight, approx	1715-OF8I module: 340 g (11.99 oz) I/O base unit: 133 g (5 oz) Termination assembly: 133 g (5 oz), 260 g (10 oz)
Dimensions (H x W x D), approx	166 x 42 x 118 mm (6.5 x 1.625 x 4.625 in.)
Wire size	1715-TASOF8I, 1715-TADOF8I I/O connections: Single 0.33...1.5 mm ² (22...16 AWG) solid or stranded shielded copper wire rated at 85 °C (185 °F), or greater
Wiring category	2 - on shielded signal ports ⁽¹⁾

Table 15 - Technical Specifications - 1715-OF8I Analog Output Module, 1715-A310 Module Base, and 1715-TASOF8I, 1715-TADOF8I Termination Assemblies

Attribute	1756-OF8I, 1715-A310, 1715-TASOF8, 1715-TADOF8
Wire type	Shielded
North American temperature code	T4
IEC temperature code	T4
Enclosure type	None (open-style)

(1) Use this conductor category information for planning conductor routing as described in the system-level installation manual. See the Industrial Automation Wiring and Grounding Guidelines, publication [1770-4.1](#).

Table 16 - Environmental Specifications - 1715-OF8I Analog Output Module, 1715-A310 Module Base, and 1715-TASOF8I, 1715-TADOF8I Termination Assemblies

Attribute	1756-OF8I, 1715-A310, 1715-TASOF8, 1715-TADOF8
Temperature, operating IEC 60068-2-1 (Test Ad, Operating Cold), IEC 60068-2-2 (Test Bd, Operating Dry Heat), IEC 60068-2-14 (Test Nb, Operating Thermal Shock)	-25...70 °C (-13...158 °F)
Temperature, surrounding air, max	70 °C (158 °F)
Temperature, nonoperating IEC 60068-2-1 (Test Ab, Unpackaged Nonoperating Cold), IEC 60068-2-2 (Test Bb, Unpackaged Nonoperating Dry Heat), IEC 60068-2-14 (Test Na, Unpackaged Nonoperating Thermal Shock)	-40...85 °C (-40...185 °F)
Relative humidity IEC 60068-2-30 (Test Db, Unpackaged Nonoperating Damp Heat)	10...95% noncondensing
Vibration IEC 60068-2-6 (Test Fc, Operating)	2 g @ 10...500 Hz
Shock, operating IEC 60068-2-27 (Test Ea, Unpackaged Shock)	DIN rail mount: 25 g Panel mount: 30 g
Shock, nonoperating IEC 60068-2-27 (Test Ea, Unpackaged Shock)	Installed: 30 g Uninstalled: 50 g (with slot fillers)
Emissions CISPR 11 (IEC 61000-6-4)	Class A
ESD immunity IEC 61000-4-2	6 kV contact discharges 8 kV air discharges
Radiated RF immunity IEC 61000-4-3	20V/m with 1 kHz sine-wave 80% AM from 80...1000 MHz 10V/m with 1 kHz sine-wave 80% AM from 1000...2000 MHz 10V/m with 200 Hz 50% Pulse 100% AM @ 900 MHz 10V/m with 200 Hz 50% Pulse 100% AM @ 1890 MHz 3V/m with 1 kHz sine-wave 80% AM from 2000...2700 MHz
EFT/B immunity IEC 61000-4-4	±2 kV @ 5 kHz on shielded signal ports
Surge transient immunity IEC 61000-4-5	±2 kV line-earth (CM) on shielded signal ports
Conducted RF immunity IEC 61000-4-6	10V rms with 1 kHz sine-wave 80% AM from 150 kHz...80 MHz

Table 17 - Certifications - 1715-OF8I Analog Output Module, 1715-A3IO Module Base, and 1715-TASOF8, 1715-TADOF8 Termination Assemblies

Certification ⁽¹⁾	1756-OF8I, 1715-A3IO, 1715-TASOF8, 1715-TADOF8
cULus	UL Listed Industrial Control Equipment, certified for US and Canada. See UL File E341697. UL Listed for Class I, Division 2 Group A,B,C,D Hazardous Locations, certified for U.S. and Canada. See UL File E251761.
CE	European Union 2004/108/EC EMC Directive, compliant with: <ul style="list-style-type: none"> • EN 61326-1; Meas./Control/Lab., Industrial Requirements • EN 61000-6-2; Industrial Immunity • EN 61000-6-4; Industrial Emissions • EN 61131-2; Programmable Controllers (Clause 8, Zone A & B)
C-Tick	Australian Radiocommunications Act, compliant with: AS/NZS CISPR 11; Industrial Emissions
Ex	European Union 94/9/EC ATEX Directive, compliant with: <ul style="list-style-type: none"> • EN 60079-15; Potentially Explosive Atmospheres, Protection 'n' • EN 60079-0; General Requirements II 3 G Ex nA IIC T4 Gc X • DEMKO 11 ATEX 7928686X
IECEx	IECEx Hazardous Location approval, compliant with: <ul style="list-style-type: none"> • IEC 60079-0: Ed 6 Explosive Atmospheres - General Requirements • IEC 60079-15: Ed 4 Explosive Atmospheres - Protection 'n' • IECEx UL 15.0032X
KC	Korean Registration of Broadcasting and Communications Equipment, compliant with: Article 58-2 of Radio Waves Act, Clause 3
Functional Safety	TÜV Certified for Functional Safety ⁽²⁾ : Capable of SIL 2 according to EN 62061, IEC 61508, and EN 61326-3-1

(1) When marked. See the Product Certification link at <http://www.ab.com> for Declarations of Conformity, Certificates, and other certification details.

(2) When used with specified firmware revisions.

1715 Redundant I/O System Accessories

Table 18 - 1715 Module Slot Filler

Cat. No.	Description	Weight, approx, g (oz)
1715-N2S	Short blank slot filler	40 (1.41)
1715-N2T	Tall blank slot filler	50 (1.76)

1715-C2 Expansion Cable

Adapter and module I/O base units can be connected via expansion cables to allow for system space requirements. The entire length of the system, including the backplane and expansion cables, cannot exceed 10 m.

Table 19 - Technical Specifications - 1715 Expansion Cable

Attribute	1715-C2
Supply voltage	50V
Dimensions, approx	2 m
Weight, approx	
Cable assembly:	570 g (20 oz)
Cable plug assembly:	50 g (2 oz)
Cable socket assembly:	50 g (2 oz)
Screw torque	0.5 N•m (0.37 lb•ft)
Screwdriver width	0.4 x 2.0 mm (0.0156 x 0.0781 in.)

Additional Resources

These documents contain additional information concerning related products from Rockwell Automation.

Resource	Description
1715 Redundant I/O System User Manual, publication 1715-UM001	Provides information that is required to install, configure, operate, and maintain the adapter for a redundant I/O system and I/O modules.
Industrial Automation Wiring and Grounding Guidelines, publication 1770-4.1	Provides general guidelines for installing a Rockwell Automation® industrial system.
Product Certifications website, http://www.ab.com	Provides declarations of conformity, certificates, and other certification details.

You can view or download publications at <http://www.rockwellautomation.com/literature/>. To order paper copies of technical documentation, contact your local Allen-Bradley distributor or Rockwell Automation sales representative.

Notes:

Important User Information

Read this document and the documents listed in the additional resources section about installation, configuration, and operation of this equipment before you install, configure, operate, or maintain this product. Users are required to familiarize themselves with installation and wiring instructions in addition to requirements of all applicable codes, laws, and standards.

Activities including installation, adjustments, putting into service, use, assembly, disassembly, and maintenance are required to be carried out by suitably trained personnel in accordance with applicable code of practice.

If this equipment is used in a manner not specified by the manufacturer, the protection provided by the equipment may be impaired.

In no event will Rockwell Automation, Inc. be responsible or liable for indirect or consequential damages resulting from the use or application of this equipment.

The examples and diagrams in this manual are included solely for illustrative purposes. Because of the many variables and requirements associated with any particular installation, Rockwell Automation, Inc. cannot assume responsibility or liability for actual use based on the examples and diagrams.

No patent liability is assumed by Rockwell Automation, Inc. with respect to use of information, circuits, equipment, or software described in this manual.

Reproduction of the contents of this manual, in whole or in part, without written permission of Rockwell Automation, Inc., is prohibited.

Documentation Feedback

Your comments will help us serve your documentation needs better. If you have any suggestions on how to improve this document, complete this form, publication [RA-DU002](#), available at <http://www.rockwellautomation.com/literature/>.

Rockwell Automation maintains current product environmental information on its website at <http://www.rockwellautomation.com/rockwellautomation/about-us/sustainability-ethics/product-environmental-compliance.page>.

Allen-Bradley, Rockwell Software, Rockwell Automation, and LISTEN. THINK. SOLVE are trademarks of Rockwell Automation, Inc. Trademarks not belonging to Rockwell Automation are property of their respective companies.

Rockwell Otomasyon Ticaret A.Ş., Kar Plaza İş Merkezi E Blok Kat:6 34752 İçerenköy, İstanbul, Tel: +90 (216) 5698400

www.rockwellautomation.com

Power, Control and Information Solutions Headquarters

Americas: Rockwell Automation, 1201 South Second Street, Milwaukee, WI 53204-2496 USA, Tel: (1) 414.382.2000, Fax: (1) 414.382.4444

Europe/Middle East/Africa: Rockwell Automation NV, Pegasus Park, De Kleetlaan 12a, 1831 Diegem, Belgium, Tel: (32) 2 663 0600, Fax: (32) 2 663 0640

Asia Pacific: Rockwell Automation, Level 14, Core F, Cyberport 3, 100 Cyberport Road, Hong Kong, Tel: (852) 2887 4788, Fax: (852) 2508 1846

United Kingdom: Rockwell Automation Ltd, Hall Road, Maldon, Essex CM94LA, UK, Tel: (44) 1621 854444, Fax: (44) 1621 851531